

## hl 3/10/16

The Scanhugger HL 3/10/16 is an all-round shredder, capable of shredding all types of woodwaste (solid wood, particleboard, MDF, pallets, cardboard, paper) depending on the material to be processed and the desired chip quality, the machine can be mounted with different screen sizes.

Scanhugger HL 3/10/16 er en all-round træknuser, der er velegnet til knusning af alle typer træaffald (massivt træ, spånplade, MDF, paller, pap, papir, kartonageaffald). Afhængig af materialetype og ønsket flisstørrelse kan maskinen monteres med forskellige soldperforeringer til henholdsvis fine/grove flistyper.

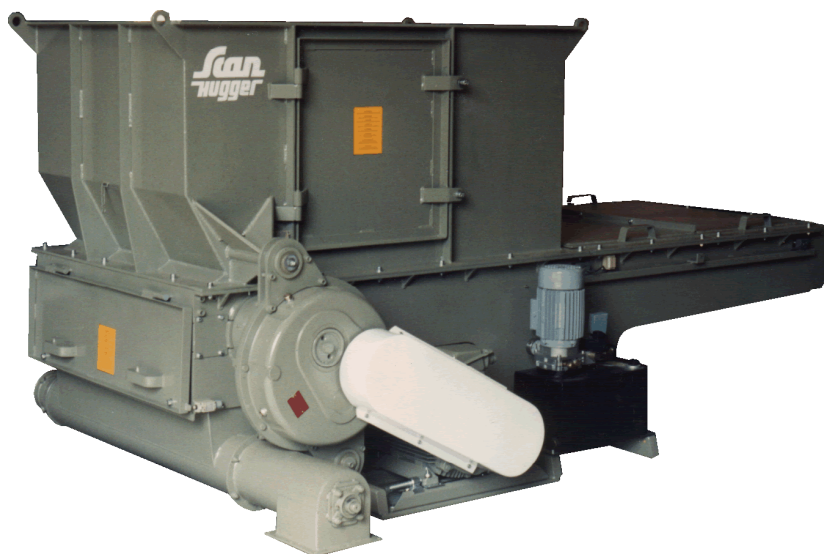

Rotor/knife  
Rotor/kniv



screen  
sold

### Technical data / Tekniske data.

Hopper dimension / Magasinmål		1028 x 1607 mm
Hopper volume / Magasinindhold		1,6 cbm
Rotor diameter / Rotor diameter		Ø 240 mm
No. of knives / Knivantal	*	30
No. of counterknives / Antal modstål		2
Rotor speed / Rotoromdrejninger	**	80 - 100 <sup>-1</sup>
Main motor / Hovedmotor	**	15 - 22 kW
Screen perforation / Soldperforering	**	15 - 40 mm
Chip length / Flislængde	**	20 - 40 mm
Capacity / Kapacitet	**	250-750kg/60min
Weight / Vægt		2900 kg
Sound level / Lydtrykniveau L <sub>pa</sub>	***	81 dB

\* Depending on rotor and type of knife

\*\* Depending on motor size, material and screen perforation

\*\*\* In accordance with ISO/DIS 11204, prEN 691

Technical alterations reserved / Ret til tekniske ændringer forbeholdes

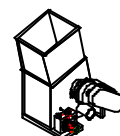

HL 2 SERIE

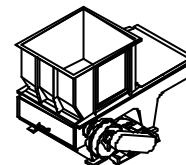

HL 3 SERIE

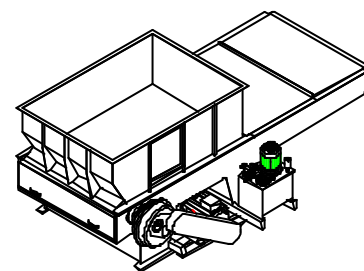

HL 4 SERIE

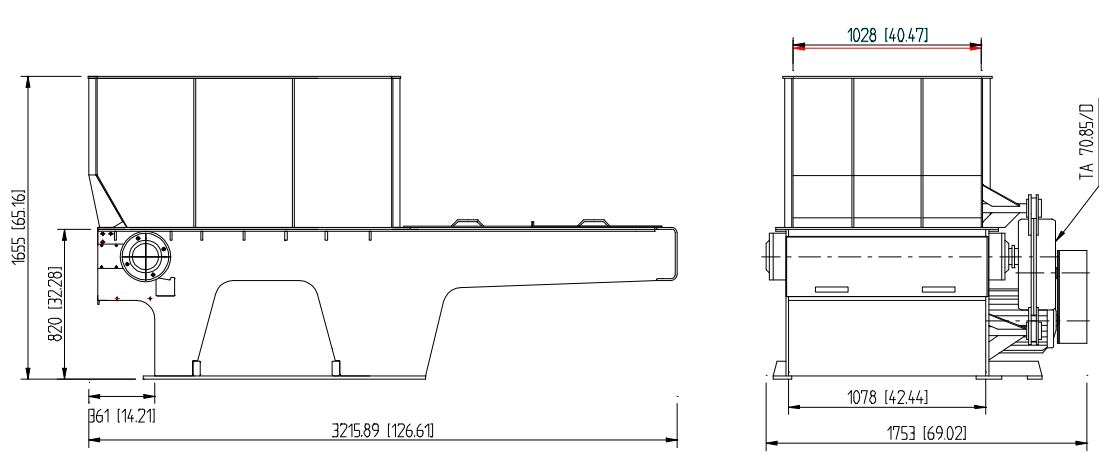

HOPPER TOP FLANGE

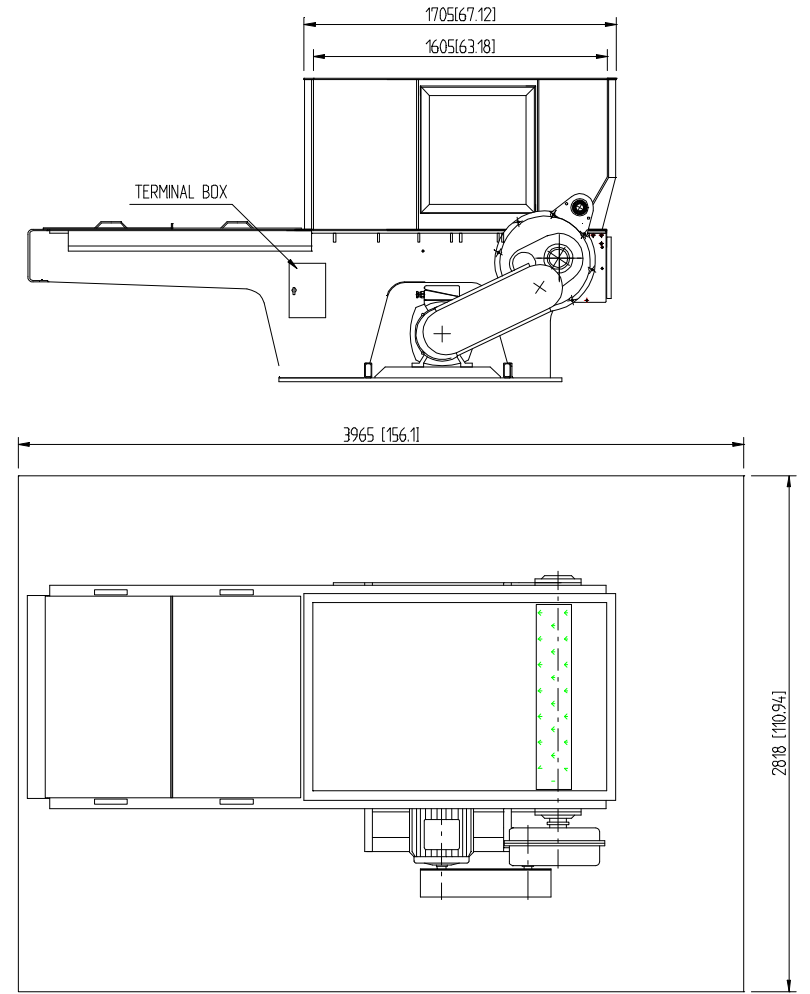

RECOMMENDED INSTALLATION DIMENSIONS

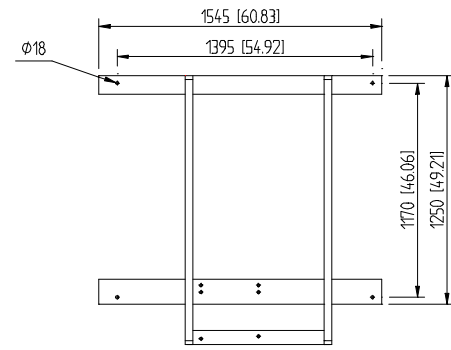

FOOTPRINT

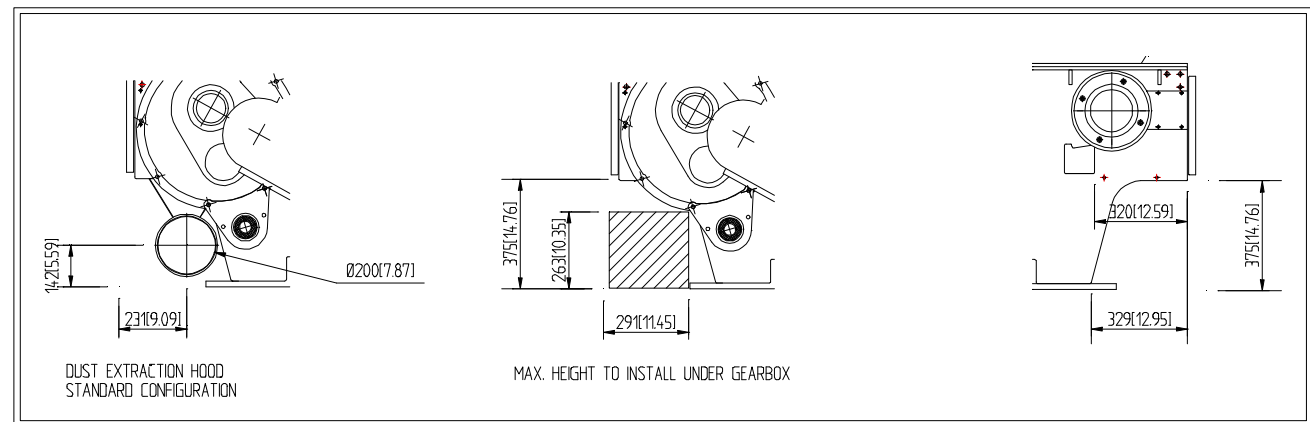
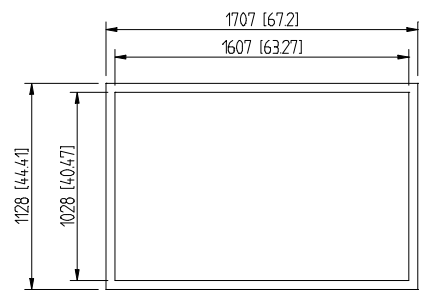

STANDARD CONFIGURATION FOR GEAR AND MOTOR MOUNTED ON LEFT SIDE  
 DIMENSIONS IN MM (INCHES)  
 REFER TO MACHINE DESCRIPTION FOR FURTHER INFORMATION

MAIN MOTOR FRAME/HP/VOLTAGE  
 HYDRAULIC POWER PACK HP/VOLTAGE  
 CONTROL VOLTAGE  
 SCREEN HOLE SIZE  
 CHIP DISCHARGE SYSTEM

ALL TECHNICAL ALTERATIONS RESERVED

Pos.nr	Mgd.	Benevnelse	Formal	Skala	Bemærkning	
Konst	Sign				Erstatter	Erstattes af
 <b>HEDETRÆ A/S</b> DK 6960 RINGKØBING TEL 9734 3111 FAX 9734 3175					Titel	Fit
					Tegningsnummer	

Denne tegning må ikke kopieres eller på nogen anden måde gøres tilgængelig for tredjepart  
 This drawing is not to be copied, printed or to be available to any unauthorized person without our specific permission