

hl 4/18/25

Scanhugger HL 4/18/25 is an all-round shredder, capable of shredding all types of woodwaste (solid wood, particleboard, MDF, pallets, cardboard, paper, demolition waste wood) depending on the material to be processed and the desired chip quality, the machine can be mounted with 2 different rotor types and various screen sizes.

Scanhugger HL 4/18/25 er en all-round træknuser, der er velegnet til knusning af alle typer træaffald (massivt træ, spånplade, MDF, paller, pap, papir, kartonageaffald). Afhængig af materialetype og ønsket flisstørrelse kan maskinen monteres med 2 rotortyper til henholdsvis fine/grove flistyper.



Rotor/knife
Rotor/kniv



screen
sold

Technical data / Tekniske data.

| | | |
|---|-----|------------------------|
| Hopper dimension / Magasinmål | | 1758 x 2515 mm |
| Hopper volume / Magasinindhold | | 3,7 cbm |
| Rotor diameter / Rotor diameter | | Ø 370 mm |
| No. of knives / Knivantal | * | 50 / 32 |
| No. of counterknives / Antal modstål | | 4 |
| Rotor speed / Rotoromdrejninger | ** | 80 - 100 ⁻¹ |
| Main motor / Hovedmotor | ** | 55 - 90 kW |
| Screen perforation / Soldperforering | ** | 30 - 100 mm |
| Chip length / Flislængde | ** | 40 - 200 mm |
| Capacity / Kapacitet | ** | 1500-8000kg/60min |
| Weight / Vægt | | 9000 kg |
| Sound level / Lydtrykniveau L _{pa} | *** | 86,5 dB |

* Depending on rotor and type of knife

** Depending on motor size, material and screen perforation

*** In accordance with ISO/DIS 11204, prEN 691

Technical alterations reserved / Ret til tekniske ændringer forbeholdes

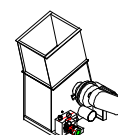

HL 2 SERIE

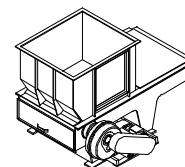

HL 3 SERIE

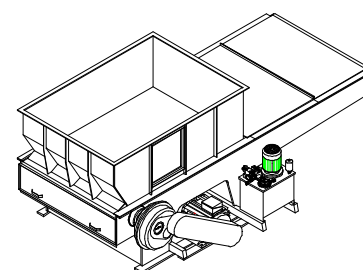

HL 4 SERIE

Scanhugger a/s
Herningvej 144 - 6950 Ringkøbing
Tel. +45 9734 3111 Fax. +45 9734 3175
www.scanhugger.com

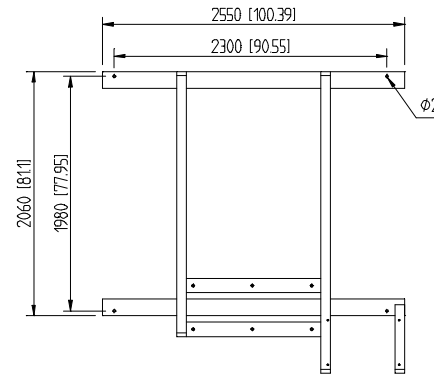
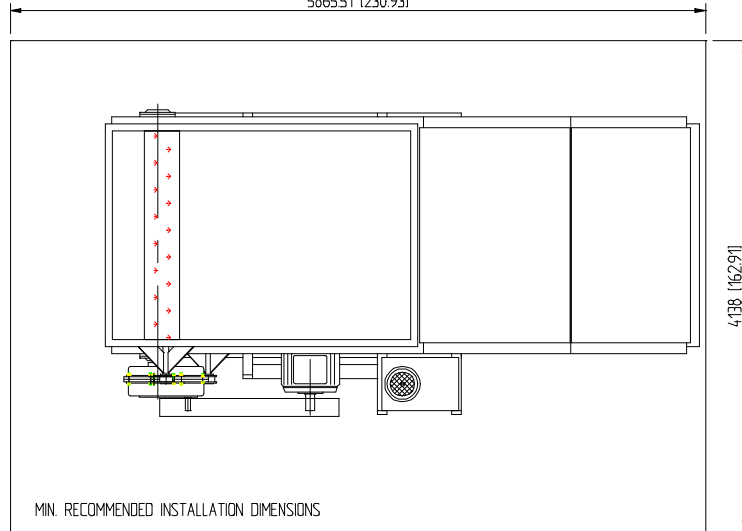
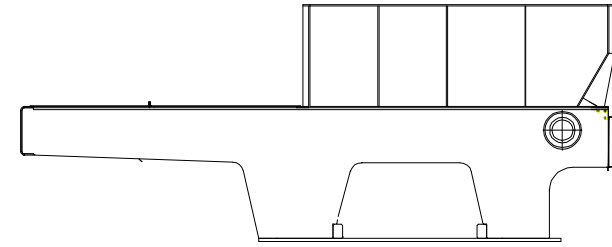
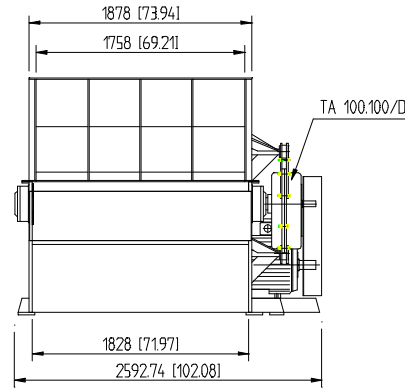
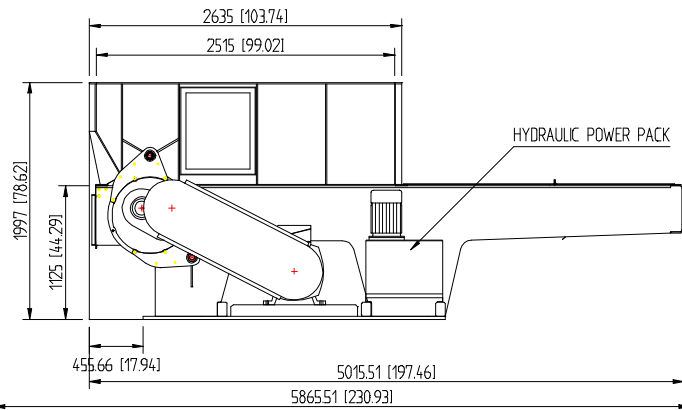

FOOTPRINT

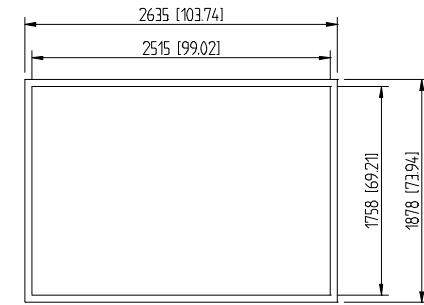

HOPPER FLANGE

MAX. INSTALLATION HEIGHT/WIDTH UNDER GEARBOX

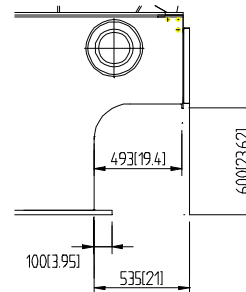
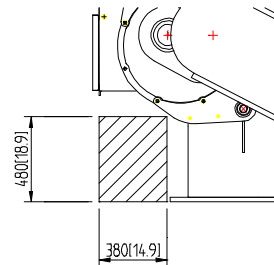

STANDARD CONFIGURATION WITH GEAR AND MOTOR MOUNTED ON LEFT SIDE
ALL DIMENSIONS IN MM (INCHES)

MAIN MOTOR FRAME SIZE 55 - 90 KW
HYDRAULIC MOTOR 75 KW
CONTROL POWER
SCREEN PERFORATION 20-80 MM
CHIP TRANSPORT SYSTEM DISCHARGE SCREW/CONVEYOR

ALL TECHNICAL ALTERATIONS RESERVED

| Pos.nr | Mgd. | Ben?vnelse | Formal | Skala | Bem?rkning | |
|---|------|------------|--------|-------|---|--------------|
| Konst | Sign | | | | Erstatter | Erstalles af |
|  | | | | | Titel | |
| | | | | | Tegningsnummer | |
| HEDETR? A/S DK 8950 RINGK?BYING TLF. 9734 3111 FAX. 9734 3175 | | | | | denne tegning m? ikke kopieres eller p? nogen anden m?de g?res tilg?ngelig for tredjepart this drawing is not to be copied, printed or to be available to any unauthorized person without our specific permission | |