

# ht 75/60/4

The Scanhugger HT 75/60/4 horizontal feed chipper is ideally suited for cutting rib edgings, slabs and off-cuts to a precise chip. The chipper can be placed in the factory at the source of waste. Operating in-line with a straight-gang rib saw, it continuously reduces the waste produced and eliminates the handling of slabs and edgings.

Scanhugger HT 75/60/4 tromlehugger er konstrueret til kontinuerlig reduktion af lange fraskær, skaller og kapender til flis. Maskinen monteres med rotor, motor og sold til den ønskede flislængde. Maskinen kan leveres med individuelt tilpasset transportudstyr, vibrende, båndtransportør og doseringsanlæg.

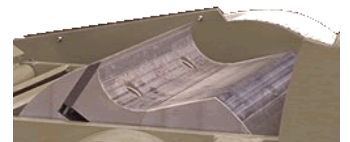

solid steel rotor with  
knife wedge mounting system  
massiv stålrotor  
montering kniv/knivkile



uniform chip  
chip size 5-25 mm  
ensartet flis  
flislængde 5-35 mm

### Technical data / Tekniske data.

Infeed height/width / Indføringsmål		180 x 730 mm
Rotor diameter / Rotordiameter		Ø 650 mm
No. of knives / Knivantal	*	2/3
Rotor speed/ Rotoromdrejninger	**	900 <sup>-1</sup>
Infeed speed / Indføringshastighed	**	25-30 m / min.
Main motor / Hovedmotor	**	55 - 110 kW
Screen perforation / Soldperforering	**	20 - 60 mm
Chip length / Flislængde	**	5 - 35 mm
Capacity / Kapacitet	**	1500-6000 kg/hr.
Weight / Vægt		5900 kg

\* Depending on rotor and type of knife  
 \*\* Depending on motor size, material and screen perforation  
 Technical alterations reserved/ Ret til tekniske ændringer forbeholdes

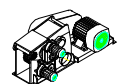

HT 25 SERIE

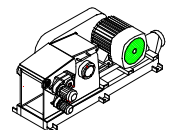

HT 35 SERIE

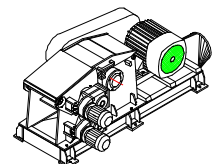

HT 45 SERIE

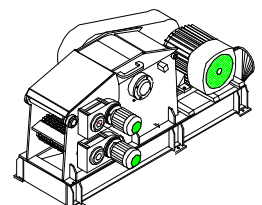

HT 60 SERIE

**Scanhugger a/s**  
 Herningvej 144 - 6950 Ringkøbing  
 Tel. +45 9734 3111 Fax. +45 9734 3175  
 www.scanhugger.com

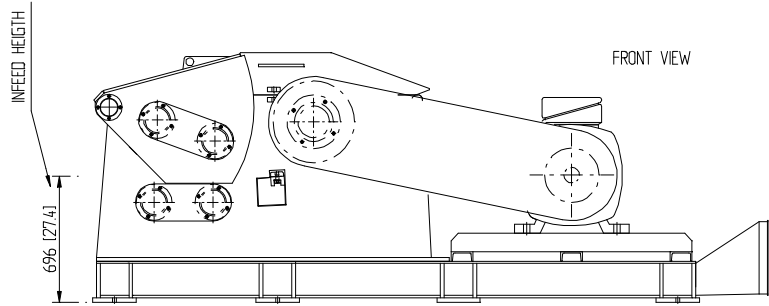

FRONT VIEW

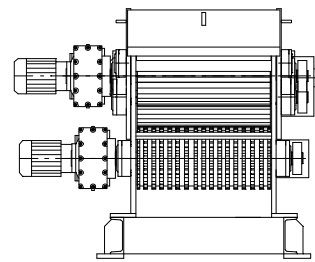

FRONT VIEW

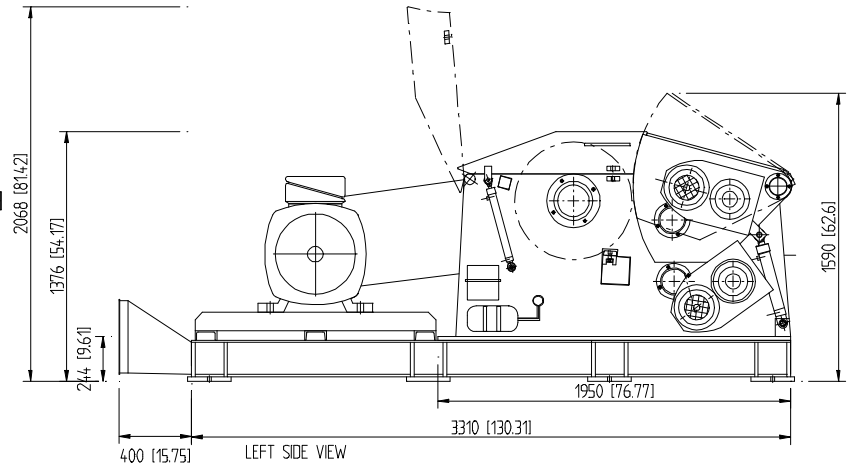

LEFT SIDE VIEW

RIGHT SIDE VIEW

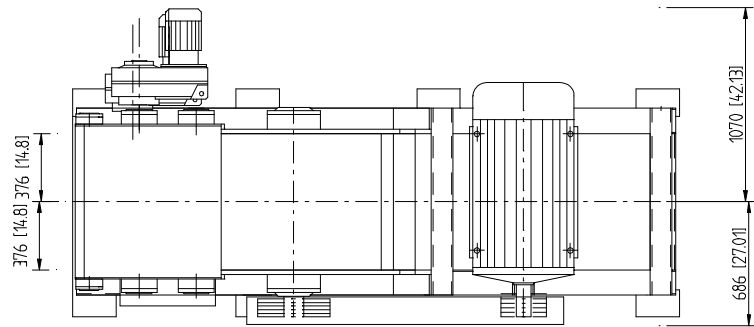

TOP VIEW

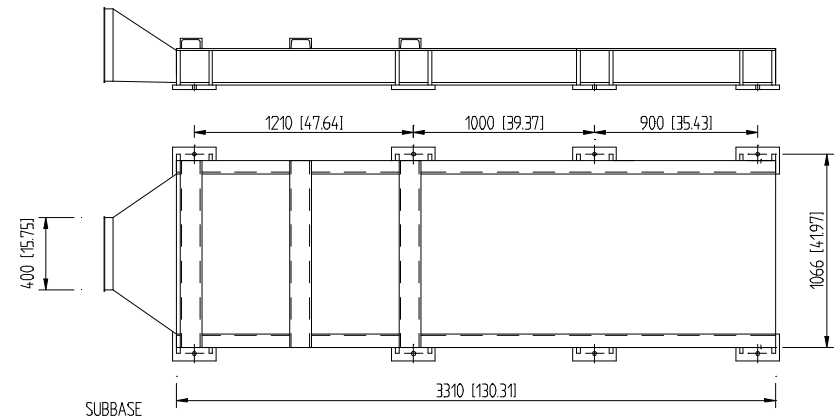

SUBBASE

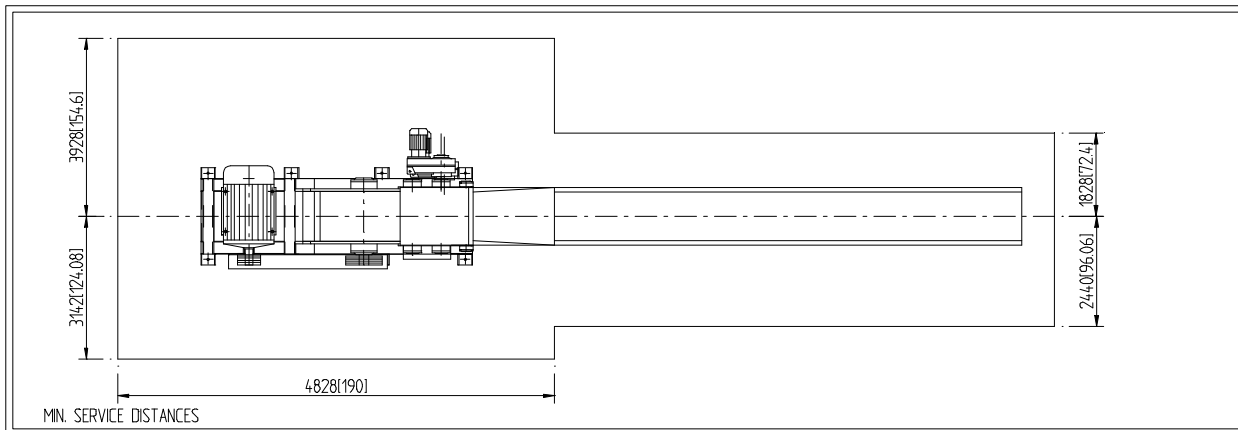

MIN. SERVICE DISTANCES

STANDARD CONFIGURATION FOR MOTOR MOUNTED ON RIGHT SIDE  
 MOTOR MOUNTED LEFT SIDE MIRROR THE MACHINE  
 DIMENSIONS IN MM(INCHES)  
 REFER TO MACHINE DESCRIPTION FOR FURTHER INFORMATION

ALL TECHNICAL ALTERATIONS RESERVED

MAIN MOTOR FRAME SIZE:  
 MAIN MOTOR HP/VOLTAGE:  
 GEARMOTOR 1 TYPE/HP:  
 GEARMOTOR 2 TYPE/HP:  
 SUBBASE:  
 SCREEN SIZE:  
 INFEED CONVEYOR:

Pos.nr	Mgd.	Betegnelse	Format	Skala	Bemærkning	
Konst	Sign				Erstatter	Erstattes af
 <b>HEDETRE A/S</b> DK-6060 BRANDØBING TEL 9734 3111 FAX 9734 3175					Titel	
					denne tegning må ikke kopieres eller på nogen anden måde gøres tilgængelig for tredjepart this drawing is not to be copied, printed or to be available to any unauthorized person without our specific permission	
					Titel	Dato
					Tegningsnummer	